

This document contains confidential and proprietary information of CARSAN ENGINEERING, Inc. The contents of this drawing shall not be disclosed, reproduced, duplicated, disseminated or used for purposes other than authorized in writing by CARSAN ENGINEERING, Inc.

PART NO: **01044-00001**

FOR REFERENCE ONLY

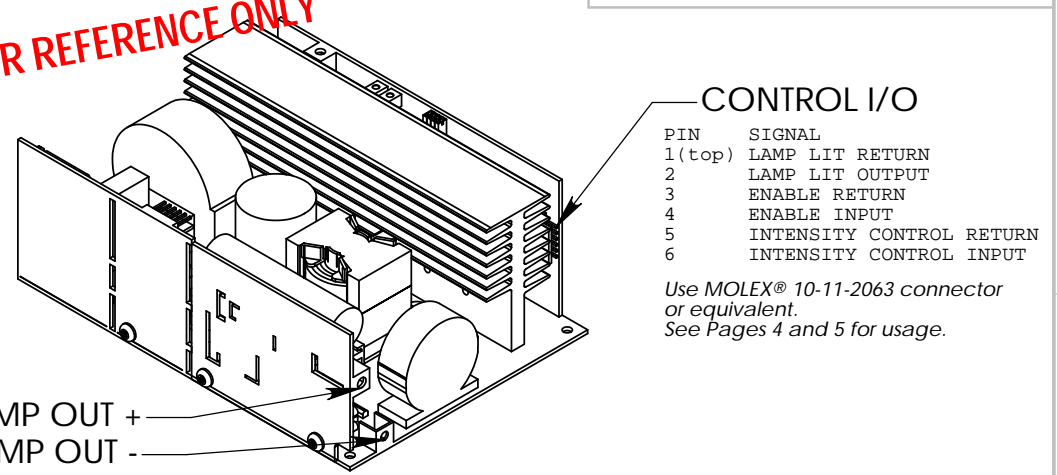

Use #6 ring or fork terminals.

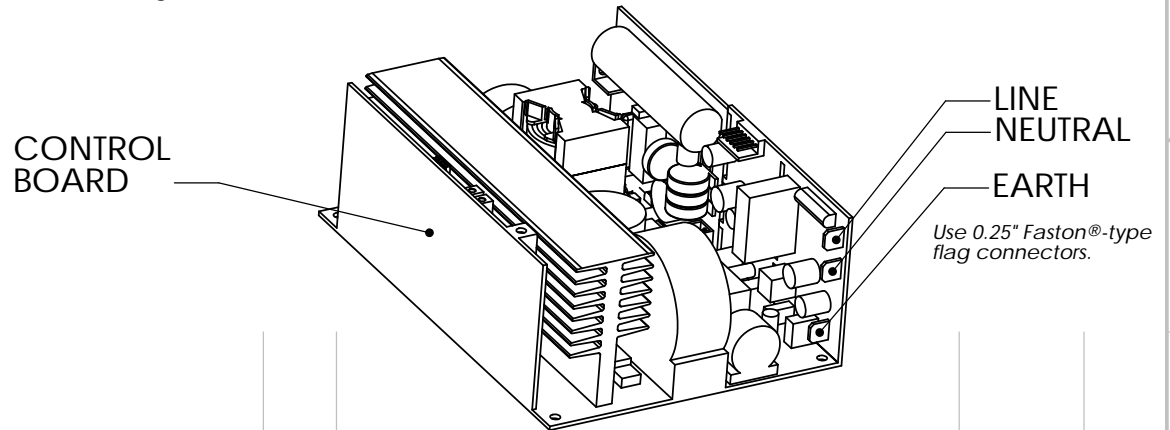

**FOR MODELS CEP300AXE, CEP300BXE, CEP300CXE
CEP300AHX, CEP300BHX, CEP300CHX**

ECO #	Description	Date	REV.
ENGINEERING CHANGE RECORD			
UNLESS OTHERWISE SPECIFIED Dimension are in inches. TOLERANCES ARE: DECIMALS ANGLES .XX: +/- .015 .XX: +/- 0.5 deg .XXX: +/- .005		CAD GENERATED DRAWING. DO NOT MANUALLY UPDATE	
MATERIAL --		APPROVALS DATE	
FINISH --		DRAWN del Cid 02-04-2002	
DO NOT SCALE DRAWING		CHECKED del Cid 02-04-2002	
		RESP ENG del Cid 02-04-2002	
		QUAL ENG Bocast 02-04-2002	
		SIZE DWG. NO. REV.	
		A 93544-00001 A	
		SCALE SHEET 1 OF 5	

CARSAN ENGINEERING, Inc.
5805 West 6th Ave, Unit 1C
Lakewood, CO 80214
303-237-9608, Fax: 303-237-0757

**CEP300 XENON
POWER SUPPLY**

93544-00001

92100-04001 A.siddrt

This document contains confidential and proprietary information of CARSAN ENGINEERING, Inc. The contents of this drawing shall not be disclosed, reproduced, duplicated, disseminated or used for purposes other than authorized in writing by CARSAN ENGINEERING, Inc.

PART NO: **01044-00001**

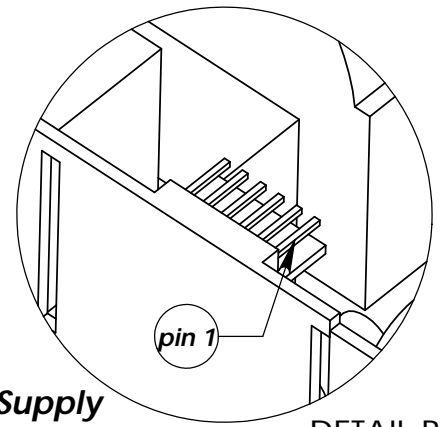
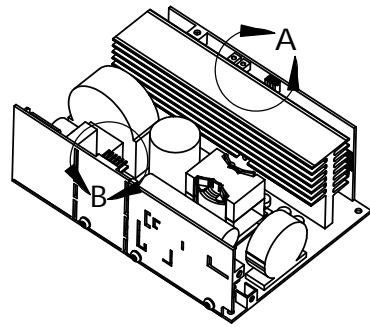

Low Voltage Power Supply (SELV Rated)

Pins 1,2,3 : +12VDC, 2.0A
Pins 4,5,6: Return

Use MOLEX® 10-11-2063 connector or equivalent.

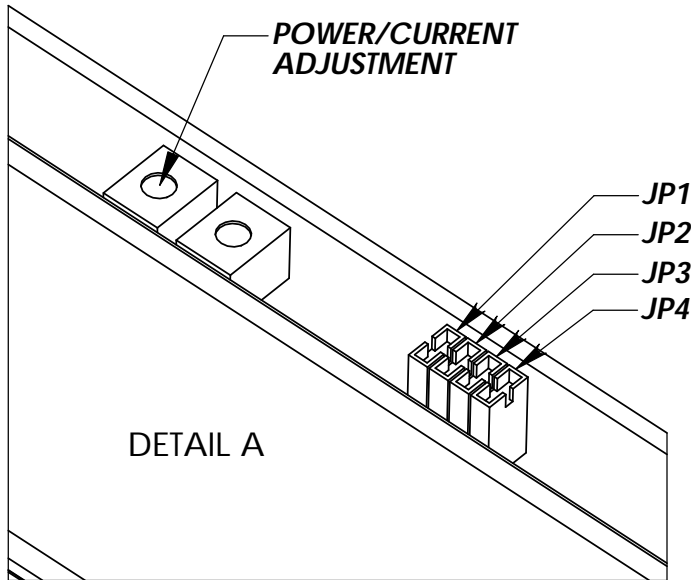

JUMPER TABLE				
	JP1	JP2	JP3	JP4
POWER CONTROL	O	I	X	X
CURRENT CONTROL	I	O	X	X
TIMER DISABLED	X	X	I	X
LAMP ENABLED	X	X	X	I

LEGEND: I JUMPER IN
O JUMPER OUT
X DON'T CARE

TEST POINTS:
TP0: SIGNAL GROUND
TP3: LAMP CURRENT (100mV/A)
TP5: LAMP POWER (10mV/W)

NOTES:
Test points are accessible through the control board.
Test points are to be used for evaluation only.

ECO #	Description	Date	REV.
ENGINEERING CHANGE RECORD			
UNLESS OTHERWISE SPECIFIED Dimension are in inches.		CAD GENERATED DRAWING. DO NOT MANUALLY UPDATE	
TOLERANCES ARE:		CARSAN ENGINEERING, Inc. 5805 West 6th Ave, Unit 1C Lakewood, CO 80214 303-237-9608, Fax: 303-237-0757 CEP300 XENON POWER SUPPLY	
DECIMALS	ANGLES		
.XX: +/- .010 .XXX: +/- .005	.XX: +/- 0.5 deg		
MATERIAL	--	APPROVALS	DATE
FINISH	--	DRAWN	del Cid 02-04-2002
DO NOT SCALE DRAWING		CHECKED	del Cid 02-04-2002
		RESP ENG	del Cid 02-04-2002
		QUAL ENG	Bocast 02-04-2002
SIZE		DWG. NO.	REV.
A		93544-00001	A
SCALE		SHEET 2 OF 5	

92100-04001 A.siddrt

This document contains confidential and proprietary information of CARSAN ENGINEERING, Inc. The contents of this drawing shall not be disclosed, reproduced, duplicated, disseminated or used for purposes other than authorized in writing by CARSAN ENGINEERING, Inc.

PART NO: **01044-00001**

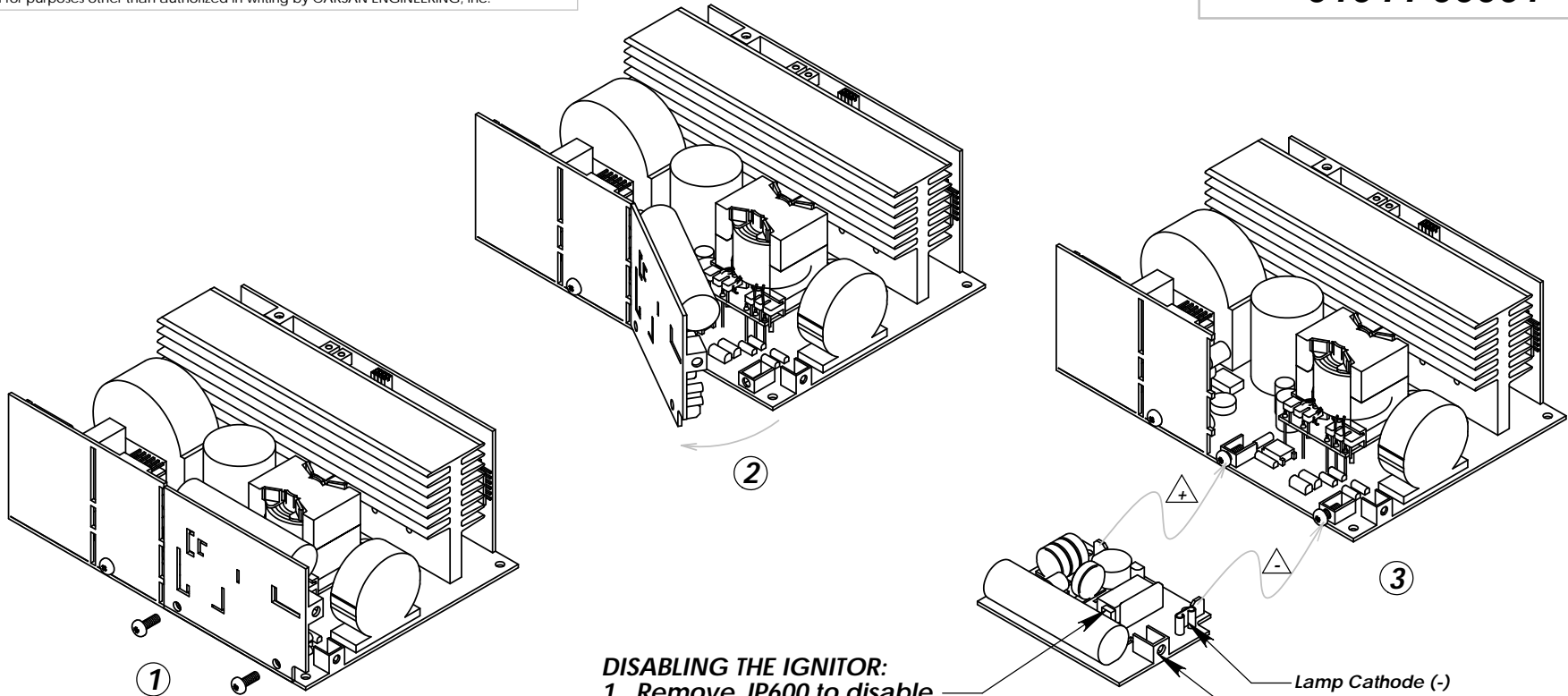

DISABLING THE IGNITOR:

1. Remove JP600 to disable.

REMOVING THE IGNITOR:

1. Remove ignitor mounting screws.
2. Tear ignitor in the direction shown.
3. Connect ignitor using 12AWG, 600V (min) wire.
PS end: #6 ring or fork terminals.
Ignitor end: 0.25" Faston®-type flag terminals.
4. Connect ignitor to lamp using 12AWG, 40kV wire
UL Style 3239.

Anode (+): #6 ring or fork terminal.
Cathode (-): 0.25" Faston®-type spade terminal.

ECO #	Description	Date	REV.
ENGINEERING CHANGE RECORD			
UNLESS OTHERWISE SPECIFIED Dimension are in inches. TOLERANCES ARE: DECIMALS ANGLES .XX: +/- .010 .XX: +/- 0.5 deg .XXX: +/- .005	CAD GENERATED DRAWING. DO NOT MANUALLY UPDATE		CARSAN ENGINEERING, Inc. 5805 West 6th Ave, Unit 1C Lakewood, CO 80214 303-237-9608, Fax: 303-237-0757 CEP300 XENON POWER SUPPLY
	APPROVALS	DATE	
	DRAWN del Cid	02-20-2002	
	CHECKED del Cid	02-20-2002	
MATERIAL	--	RESP ENG del Cid	02-20-2002
FINISH	--	QUAL ENG Bocast	02-20-2002
DO NOT SCALE DRAWING		SIZE A	DWG. NO. 93544-00001
		SCALE	REV. A
			SHEET 3 OF 5

92100-04001 A.siddrt

Using TheCONTROL I/O:

The Control I/O Connector consists of two inputs and one output, each of which is optically isolated. The inputs are designed to be driven by a 5-12V source.

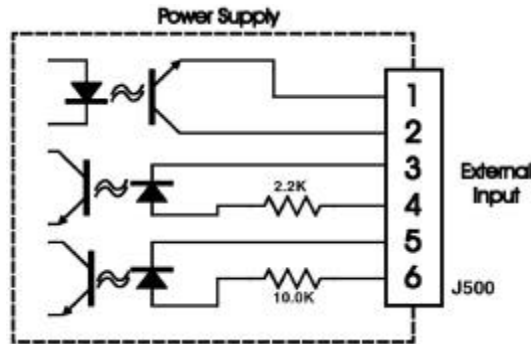

PINS 1 and 2:

The Lamp Lit output is a transistor that is on when current is flowing to the lamp. The collector current will be greater than 3.0 mA when the lamp is on. A 2.2K ohm resistor pull-up will create a TTL-compatible signal. The delay from light output from the lamp to the Lamp Lit output being asserted is less than 10 ms.

PINS 3 and 4:

The Enable input turns the lamp on and off. A high input (5-12VDC) to the Enable pin turns on the lamp. The source used must have a low impedance and be capable of supplying 2.0 mA into the circuit. The electrical delay of the enable input is less than 10 ms. To turn on the lamp, the delay of the Enable input must be added to the time to ignite the lamp, which is approximately 100 ms, for a total of 110 ms. Turning off the lamp takes only 10 ms. The auxiliary +12 V supply runs all the time, regardless of the state of the Enable input.

PINS 5 and 6:

See "Using the Lamp Intensity Control Input on the CEP300AXE Xenon Power Supply" (page 5).

ECO #	Description	Date	REV.										
ENGINEERING CHANGE RECORD													
UNLESS OTHERWISE SPECIFIED Dimension are in inches. TOLERANCES ARE: DECIMALS ANGLES .XX: +/- .010 .XX: +/- 0.5 deg .XXX: +/- .005		CAD GENERATED DRAWING. DO NOT MANUALLY UPDATE											
MATERIAL --		<table border="1"> <tr> <th>APPROVALS</th> <th>DATE</th> </tr> <tr> <td>DRAWN del Cid</td> <td>02-25-2002</td> </tr> <tr> <td>CHECKED del Cid</td> <td>02-25-2002</td> </tr> <tr> <td>RESP ENG del Cid</td> <td>02-25-2002</td> </tr> <tr> <td>QUAL ENG Bocast</td> <td>02-25-2002</td> </tr> </table>		APPROVALS	DATE	DRAWN del Cid	02-25-2002	CHECKED del Cid	02-25-2002	RESP ENG del Cid	02-25-2002	QUAL ENG Bocast	02-25-2002
APPROVALS	DATE												
DRAWN del Cid	02-25-2002												
CHECKED del Cid	02-25-2002												
RESP ENG del Cid	02-25-2002												
QUAL ENG Bocast	02-25-2002												
FINISH --		<table border="1"> <tr> <td>SIZE A</td> <td>DWG. NO. 93544-00001</td> <td>REV. A</td> </tr> </table>		SIZE A	DWG. NO. 93544-00001	REV. A							
SIZE A	DWG. NO. 93544-00001	REV. A											
DO NOT SCALE DRAWING		SCALE											
		SHEET 4 OF 5											

CARSAN ENGINEERING, Inc.
5805 West 6th Ave, Unit 1C
Lakewood, CO 80214
303-237-9608, Fax: 303-237-0757

**CEP300 XENON
POWER SUPPLY**

Using the Lamp Intensity Control Input on the CEP300 Xenon Power Supply

The Carsan Engineering power supply drives xenon lamps with a constant power or constant current. The supply provides an external input for controlling the power to the lamp. This paper provides the information needed by the system designer to take advantage of the Lamp Intensity Control input.

The power stage of the supply can be modeled as a high-gain amplifier with current and voltage feedback from the lamp. The power to the lamp is controlled by a user adjustable potentiometer that adjust the feedback from the multiplier. This determines the quiescent power to the lamp.

The Control I/O Connector provides an optoisolated input for controlling lamp power. When a voltage is applied to the Lamp Intensity input (pins 5 & 6), current flows in the diode of the optoisolator. A corresponding current flows in the coupled transistor, which injects a current into the output reference. This lowers the reference, hence reducing the power. Notice that the external input is only capable of decreasing lamp power. This is a safety feature; the lamp power can never exceed the value set by the potentiometer. The typical relationship between the external applied voltage and the lamp output is shown in Figure 1. Note that although the output power is capable of going to zero, many lamps become unstable when run at less than 30% to 50% of their rated power.

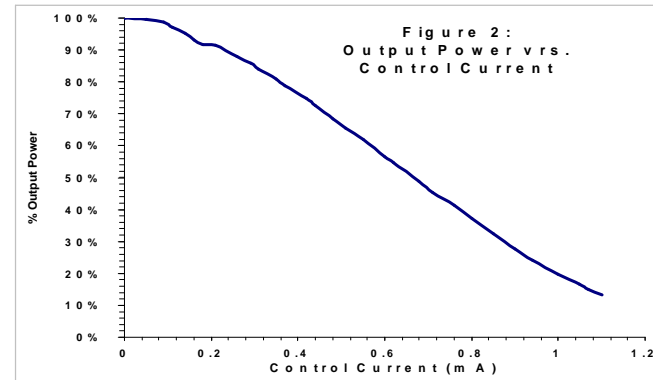
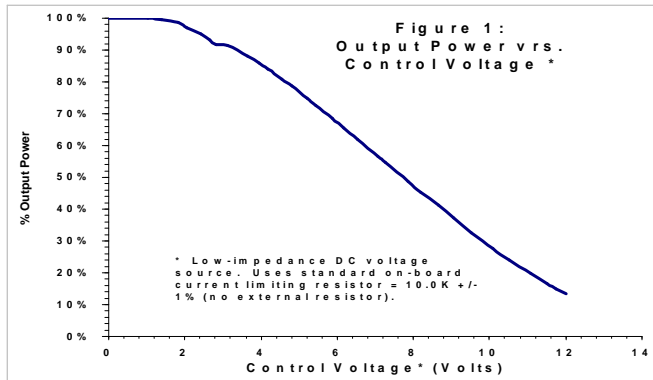

The transfer function from the external applied voltage to transistor current is not linear. This is often not a problem for closed loop feedback systems. If the feedback loop is a first order loop, or has low open-loop gain, then it may be desirable to linearize the transfer function of the optoisolator. This can be done if the input is driven with a constant current source. The transistor current will be equal to the diode current. For most applications this will require a 12V supply in order to give the driving current source enough compliance. The typical relationship between the control current and the lamp output is shown in Figure 2. The current transfer ratio (CTR) of the optoisolator is specified to stay between 100% and 200% over time and temperature.

ECO #	Description	Date	REV.
ENGINEERING CHANGE RECORD			
UNLESS OTHERWISE SPECIFIED Dimension are in inches. TOLERANCES ARE: DECIMALS ANGLES .XX: +/- .010 .XX: +/- 0.5 deg .XXX: +/- .005	CAD GENERATED DRAWING. DO NOT MANUALLY UPDATE		CARSAN ENGINEERING, Inc. 5805 West 6th Ave, Unit 1C Lakewood, CO 80214 303-237-9608, Fax: 303-237-0757 CEP300 XENON POWER SUPPLY
	DRAWN	APPROVALS DATE	
	CHECKED	del Cid 02-27-2002	
	RESP ENG	del Cid 02-27-2002	
MATERIAL --	del Cid 02-27-2002		
FINISH --	QUAL ENG Bocast 02-27-2002	SIZE DWG. NO.	REV.
DO NOT SCALE DRAWING		A 93544-00001	A
		SCALE	SHEET 5 OF 5

92100-04001 A.siddrt